

ELECTRONIC VALVE SPECIFICATIONS

SPECIFICATION CV7348-55

ISSUE NO. 1 DATED 24.9.1962

AMENDMENT No. 1

Page 11, Sub group 2, Shock;

Under Inspection Level amend I to read IA.

MINISTRY OF AVIATION/R.R.E.

June, 1964.

MILITARY SPECIFICATION

K1007/CV7348-55

Issue 1

24th Sept., 1962

# CV7348-51 NPN CV7352-55 PNP

SEMICONDUCTOR DEVICE, TRANSISTOR TYPES

2N1302, 2N1304, 2N1306, 2N1308. NPN

2N1303, 2N1305, 2N1307, 2N1309. PNP

Description:-

This specification covers the detail requirements for NPN and PNP complementary alloy-junction Germanium Transistors and is in accordance with Specification K1007, Issue 3 except as otherwise stated.

Mechanical Dimensions and Outlines: K1007 Section B.10.3.2.2 and 10.4.2.2.

Connections:-

Base connected to case.

Lead 1, Emitter      Lead 2, Base      Lead 3, Collector

Absolute Maximum Ratings:

Device	Rating	V <sub>CB</sub>	V <sub>EB</sub>	I <sub>C</sub>	I <sub>CM</sub>	I <sub>E</sub>	I <sub>B</sub>	P <sub>T</sub>	T <sub>amb</sub>	T <sub>stg</sub>
	Unit	V	V	mA	mA	mA	mA	mW	°C	°C
CV7348	Min.	-	-	-	-	-	-	-	-55	-55
-CV7351	Max.	25	25	300	400	350	50	150	+85	+100
CV7352	Min.	-	-	-	-	-	-	-	-55	-55
-CV7355	Max.	30	25	300	400	350	50	150	+85	+100
Note					3			1		

Device	Rating	V <sub>CE</sub>	Shock	Vibration
	Unit	V	g	g
CV7348	Max.	25	100	20
CV7349	Max.	20	100	20
CV7350	Max.	15	100	20
CV7351	Max.	15	100	20
CV7352	Max.	25	100	20
CV7353	Max.	20	100	20
CV7354	Max.	15	100	20
CV7355	Max.	15	100	20
Note			2	

Note 1. At 25°C case temperature P<sub>T</sub> = 300mW. See derating curve, Page 13.

Note 2. Shock duration 6 mS.

Note 3. 1 mSec. pulse rate 1%.

24th Sept., 1962.

# CV 7348-55

## Primary Electrical Characteristics:

Characteristic		$I_{CBO}$	$V_{CE(sat)}$	$f_{hfb}$	$h_{FE}$	$\tau_C$	$\tau_s$	$C_{tc}$
Unit		$\mu A$	V	Mc/s		nSec	$\mu Sec$	pF
CV7348	Min.	-	-	3	20	-	0.2	-
	Max.	6.0	0.2	-	-	64	1.0	20
CV7349	Min.	-	-	5	40	-	0.2	-
	Max.	6.0	0.2	-	200	53	1.0	20
CV7350	Min.	-	-	10	60	-	0.2	-
	Max.	6.0	0.2	-	300	20	0.9	20
CV7351	Min.	-	-	15	80	-	0.2	-
	Max.	6.0	0.2	-	-	16	0.9	20
CV7352	Min.	-	-	3	20	-	0.2	-
	Max.	6.0	0.2	-	-	80	1.0	15
CV7353	Min.	-	-	5	40	-	0.2	-
	Max.	6.0	0.2	-	200	53	1.0	15
CV7354	Min.	-	-	10	60	-	0.2	-
	Max.	6.0	0.2	-	300	27	0.9	15
CV7355	Min.	-	-	15	80	-	0.2	-
	Max.	6.0	0.2	-	-	16	0.9	15
CONDITIONS	$V_{CB}$ (V)	25	-	5	-	-	-	5
	$I_C$ (mA)	-	10	1	10	10	2	-
	$I_B$ (mA)	-	Note 1	-	-	-	2	-
	$V_{CE}$ (V)	-	-	-	0.5	0.5	-	-

Note 1. CV7348, CV7352 = 0.5mA. CV7349, CV7353 = 0.25mA  
 CV7350, CV7354 = 0.17mA. CV7351, CV7355 = 0.13mA

Reliability Assurance Requirements: Under discussion

## Requirements

Marking The device shall be marked as K1007, Issue 3, Section B, 1.3.4.1(a), (c), (d) and (f) as space permits, any other marking shall be on the packing.

## Quality Assurance Provisions

Destructive Tests The tests listed in Table 2, Group B Inspection, Sub-Groups 2 and 3 are considered destructive.

Group C Inspection This inspection shall be conducted on the initial lot, and thereafter every ninety days or every fifth lot, whichever occurs first.

## Preparation for Delivery

Packaging The device shall be packed according to K1007, Issue 3, Section A.1.2.(c).

## Joint Service Catalogue Numbers

CV7348 = 5960-99-037-2972  
CV7349 = 5960-99-037-2973  
CV7350 = 5960-99-037-2974  
CV7351 = 5960-99-037-2975  
CV7352 = 5960-99-037-2976  
CV7353 = 5960-99-037-2977  
CV7354 = 5960-99-037-2978  
CV7355 = 5960-99-037-2979

# CV7348-55

TABLE 1. GROUP A INSPECTION

Examination or Test	K1007/NATO Ref.	TEST CONDITIONS	AQL %	Insp. Level	Sym-bol	LIMITS		Units
						Min.	Max.	
<u>SUB-GROUP 1</u>								
Visual and Mechanical Inspection	5.1	Excluding Physical Dimensions	0.65	I				
<u>SUB-GROUP 2</u>								
Collector Base Cut-Off Current (1)	7.2.5.1	CV7348-51 $V_{CB} = 25V$ . $I_E = 0$	1.0	II	$I_{CBO}$	-	6	$\mu A$
		CV7352-55 $V_{CB} = 25V$ . $I_E = 0$			$I_{CBO}$	-	-6	$\mu A$
Collector-Emitter Saturation Voltage (1)	7.3.3.	$I_C = 10mA$ CV7348 $I_B = 0.5mA$ CV7349 $I_B = 0.25mA$ CV7350 $I_B = 0.17mA$ CV7351 $I_B = 0.13mA$ $I_C = -10mA$ CV7352 $I_B = -0.5mA$ CV7353 $I_B = -0.25mA$ CV7354 $I_B = -0.17mA$ CV7355 $I_B = -0.13mA$			$V_{CE(sat)}$	-	0.2	V

TABLE 1. GROUP A INSPECTION (Contd.)

Examination or Test	K1007/NATO Ref.	TEST CONDITIONS SPECIFIC CONDITIONS	AQL %	Insp. Level	Sym- bol	LIMITS		Units
						Min.	Max.	
SUB-GROUP 2 (Contd.) Common Emitter High Frequency Current Gain		f = 0.5 Mc/s V <sub>CE</sub> = 0.5 I <sub>C</sub> = 10mA			h <sub>fe</sub>			
		CV7348 CV7349				5.0 6.0		
		f = 2 Mc/s			T <sub>s</sub>			
		CV7350 CV7351				4.0 5.0		
		f = 0.5 Mc/s V <sub>CE</sub> = -0.5V I <sub>C</sub> = -10mA						
		CV7352 CV7353			5.0 6.0			
		f = 2.0 Mc/s						
		CV7354 CV7355			4.0 5.0			
		Note 1. Page 12						
		I <sub>B</sub> = 2mA. I <sub>C</sub> ≥ 2mA						
	CV7348 CV7349 CV7350 CV7351							
	I <sub>B</sub> = -2mA. I <sub>C</sub> ≥ -2mA							
	CV7352 CV7353 CV7354 CV7355							
	Note 2. Page 12							
Saturation Time Factor								
								1.0 μs 1.0 μs 0.9 μs 0.9 μs 1.0 μs 1.0 μs 0.9 μs 0.9 μs

# CV7348-55

TABLE 1. GROUP A INSPECTION (Contd.)

Examination or Test	K1007/NATO Ref.	TEST CONDITIONS SPECIFIC CONDITIONS	AQL %	Insp. Level	Sym- bol	LIMITS		Units
						Min.	Max.	
<u>SUB-GROUP 2</u> (Contd.) Transient Saturation Voltage		$I_C = 10\text{mA}$ CV7348. $I_B = 1\text{ mA}$ CV7349. $I_B = 0.75\text{mA}$ CV7350. $I_B = 0.6\text{ mA}$ CV7351. $I_B = 0.35\text{mA}$  $I_C = -10\text{mA}$ CV7352. $I_B = -1\text{mA}$ CV7353. $I_B = -0.75\text{mA}$ CV7354. $I_B = -0.60\text{mA}$ CV7355. $I_B = -0.35\text{mA}$  Note 3 Page 12.	4.0	I	$V_{ce}$	-	0.2	V
		-				-0.2	V	
<u>SUB-GROUP 3</u> Base Emitter Voltage (1)	7.3.2	$I_C = 10\text{mA}$ CV7348. $I_B = 0.5\text{mA}$ CV7349. $I_B = 0.25\text{mA}$ CV7350. $I_B = 0.17\text{mA}$ CV7351. $I_B = 0.13\text{mA}$  $I_C = -10\text{mA}$ CV7352. $I_B = -0.5\text{mA}$ CV7353. $I_B = -0.25\text{mA}$ CV7354. $I_B = -0.17\text{mA}$ CV7355. $I_B = -0.13\text{mA}$			$V_{BE}$	-	0.3	V
						-	0.3	V
						-	0.3	V
						-	0.3	V
						-	-0.3	V
						-	-0.3	V
						-	-0.3	V
						-	-0.3	V

TEST 1. GROUP A INSPECTION (Contd.)

Examination or Test	TEST CONDITIONS		AQI %	Insp. Level	Sym- bol	LIMITS		Units
	K1007/NATO Ref.	SPECIFIC CONDITIONS				Min.	Max.	
SUB-GROUP 3 (Contd.) Collector-Emitter Saturation Voltage (2)	7.3.3	$I_C = 100 \text{ mA}$ CV7348. $I_B = 6 \text{ mA}$ CV7349. $I_B = 4 \text{ mA}$ CV7350. $I_B = 3 \text{ mA}$ CV7351. $I_B = 2 \text{ mA}$ $I_C = -100 \text{ mA}$ CV7352. $I_B = -6 \text{ mA}$ CV7353. $I_B = -4 \text{ mA}$ CV7354. $I_B = -3 \text{ mA}$ CV7355. $I_B = -2 \text{ mA}$			$V_{CE}$ (set)	-	0.3	V
Static value of short-circuit forward current transfer ratio (1)	7.3.4.	$V_{CE} = 1.0 \text{ V}$ $I_C = 10 \text{ mA}$ CV7348 CV7349 CV7350 CV7351 $V_{CE} = -1.0 \text{ V}$ $I_C = -10 \text{ mA}$ CV7352 CV7353 CV7354 CV7355			$h_{FE}$	20 40 60 80	200 300	
Emitter Base Cut-off Current	7.2.6	$V_{EB} = 25 \text{ V}$ . $I_C = 0$ CV7348-51 $V_{EB} = -25 \text{ V}$ . $I_C = 0$ CV7352-55			$I_{EBO}$	-	6	$\mu\text{A}$
						-	-6	$\mu\text{A}$



TABLE 1. GROUP A INSPECTION (Contd.)

Examination or Test	TEST CONDITIONS		AQL %	Insp. Level	Sym- bol	LIMITS		Units
	K1007/NATO Ref.	SPECIFIC CONDITIONS				Min.	Max.	
<u>SUB-GROUP 3</u> (Contd.) Emitter Base Off Voltage	7.2.4	$R_{CE} = 1 \text{ Mohm}, V_{EB} = 1.0\text{v}$ CV7348. CV7349. CV7350/51. $R_{BE} = 1 \text{ Mohm}, V_{EB} = -1.0\text{v}$ CV7352. CV7353. CV7354/55.			V <sub>CB</sub>	25.0 20.0 15.0		V V V
<u>SUB-GROUP 4</u> Collector-Base Capacitance		$V_{CB} = 5\text{v.}$ CV7348-51 $V_{CB} = -5\text{v.}$ CV7352-55 $I_E = 0$ $f = 1 \text{ Mc/s}$	4.0	IA	C <sub>to</sub>	- -	20 15	pF pF
D.C. Current Gain (2)	7.3.4	$V_{CE} = 0.35\text{v.}$ I <sub>C</sub> = 200 mA CV7348 CV7349 CV7350-51 $V_{CE} = -0.35\text{v.}$ I <sub>C</sub> = -200 mA CV7352 CV7353 CV7354-55			h <sub>FE</sub>	10 15 20		
Collector-Emitter Cut-off current	7.2.5.5	$V_{CE} = 15\text{V}$ T <sub>amb</sub> = -55°C min $V_{BE}$ CV7348-51 = -0.2V $V_{BE}$ CV7352-55 = 0.2V			I <sub>CEX</sub>	10 15 20 -	50	uA

TABLE 2. GROUP B INSPECTION  
See Page 3 Quality Assurance Provisions Destructive Tests

Examination or Test	TEST CONDITIONS		AQL %	Insp. Level	Sym- bol	LIMITS		Units
	K1007/NATO Ref.	SPECIFIC CONDITIONS				Min.	Max.	
<u>SUB-GROUP 1</u> Physical Dimensions	5.1	According to drawings 10.3.2.2 and 10.4.2.2.	6.5	IA				
<u>SUB-GROUP 2</u> Solderability Temperature Cycling Thermal Shock Moisture Resistance	5.13 5.5 5.6.2 5.3.1	-55°C to +85°C 85°C and 0°C	4.0	IA				
<u>SUB-GROUP 3</u> Vibration Fatigue	5.15.1		4.0	I Note 4				
<u>SUB-GROUP 4</u> Lead Fatigue	5.10.1	2 cycles	6.5	IA				
<u>SUB-GROUP 5</u> Omitted								
<u>SUB-GROUP 6</u> Omitted								
<u>SUB-GROUP 7</u> High Temperature Life (non-operating)	6.2.1	T <sub>stg</sub> = 100°C Duration 1000 hours		Note 4				

TABLE 2. GROUP B INSPECTION (Contd.)

Examination or Test	TEST CONDITIONS		AQL %	Insp. Level	Symbol	LIMITS		Units
	K1007/NATO Ref.	SPECIFIC CONDITIONS				Min.	Max.	
<u>SUB-GROUP 8</u> Operating Life	6.3	<p><math>T_{amb} = 55^{\circ}C</math> <math>P_o = 75mW</math> Duration 1000 hrs. Alternatively <math>T_{amb}</math> may be between <math>25^{\circ}</math> and <math>65^{\circ}C</math>. <math>P_o</math> corresponding to that given on the derating curve Fig. 1 Page 13.</p>	6.5	IA				
<u>Post Test End Points for SUB-GROUPS 2-7</u>								
Collector Base Cut-off Current (1)	7.2.5.1	As in Sub Group 2 Group A			$I_{CBO}$	-	12	$\mu A$
Static forward current transfer ratio (1)	7.3.4	As in Sub Group 3 Group A CV7348 and CV7352 CV7349 and CV7353 CV7350 and CV7354 CV7351 and CV7355			$h_{FE}$	16 32 48 64	- - - -	

TABLE 2. GROUP C INSPECTION  
See Page 3 Quality Assurance Provisions Group C Inspection

Examination or Test	TEST CONDITIONS		AQL %	Insp. Level	Sym- bol	LIMITS		Units
	K1067/NATO Ref.	SPECIFIC CONDITIONS				Min.	Max.	
<u>SUB-GROUP 1</u> Collector Emitter Saturation Voltage (3)	7.3.3	$I_C = 200mA$ CV7348. $I_B = 20mA$ CV7349. $I_B = 13.3mA$ CV7350. $I_B = 10mA$ CV7351. $I_B = 10mA$ $I_C = -200mA$ CV7352. $I_B = -20mA$ CV7353. $I_B = -13.3mA$ CV7354. $I_B = -10mA$ CV7355. $I_B = -10mA$	1.0	II	V <sub>CE</sub>	-	0.35	V
Base Emitter Voltage (2)	7.3.2	$I_C = 200mA$ $I_B$ . As above, CV7348-51 $I_C = -200mA$ $I_B$ . As above, CV7352-55			V <sub>BE</sub>	-	1.0	V
Emitter Capacitance		$V_{EB} = 5V$ $I_C = 0$ $f = 1Mc/s$ OV7348-51 OV7352-55			C <sub>TE</sub>	-	20 15	pF pF
<u>SUB GROUP 2</u> Shock	5.17.1	Non-operating, 5blows in three mutually perpendicular directions	6.5	I				

NOTES

1. A suitable circuit is shewn in Figure 2. This gives a limit of  $T_c = \frac{1}{2\pi h_{fe} \cdot f}$

where  $f$  is the frequency of measurement.

2. Suitable circuits are shewn in Figures 3 and 4. Pages 15 and 16.

3. A suitable circuit is shewn in Figure 5. Page 17.

4. The sample size will not exceed 125.

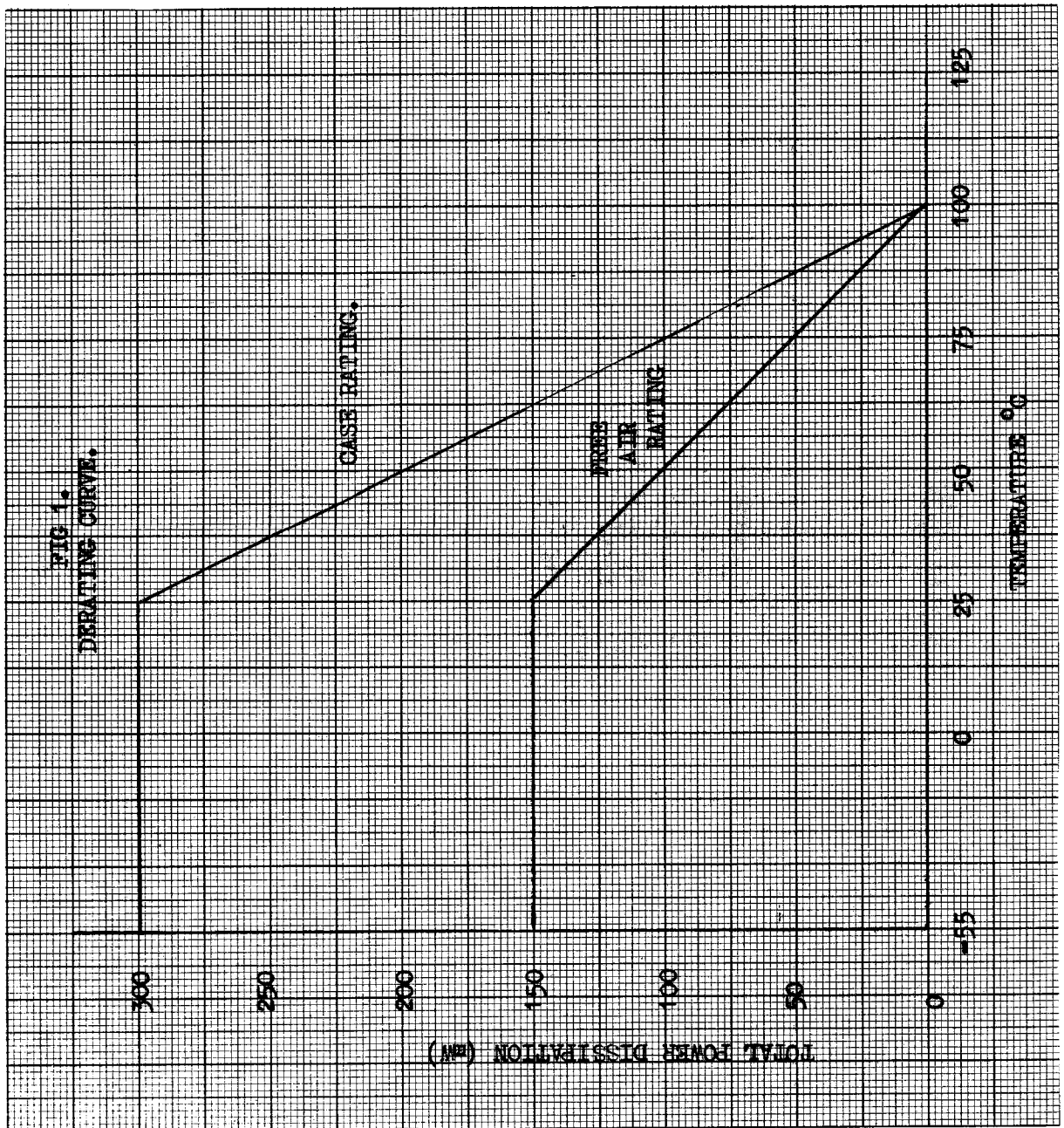
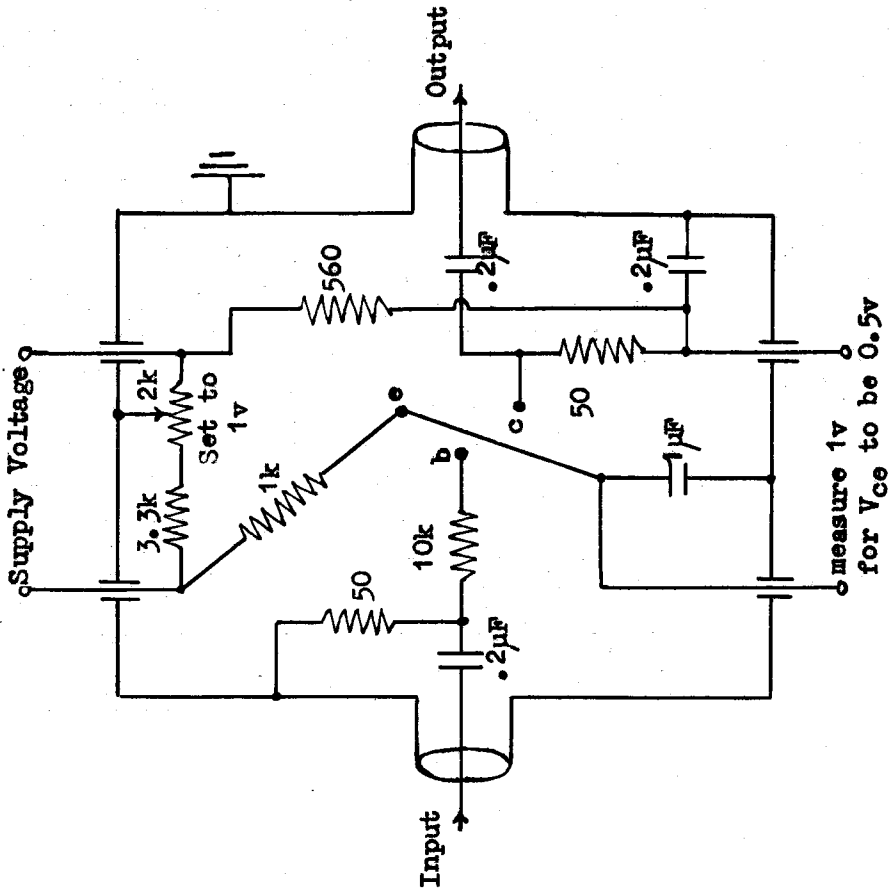

FIG 2



Test Procedure.

To set the d.c. conditions the 2K potentiometer is adjusted until the d.c. voltmeter reads 1.0 volts.

To set the a.c. condition a 0.1µF is connected between collector and base and the signal level adjusted to give a reading of 0.01 volts. On inserting the transistor the reading of the a.c. voltmeter on the output corresponds to the value of  $|h_{fe}|$

DIAGRAM FOR  $|h_{fe}|$  TEST JIG

FIG 3

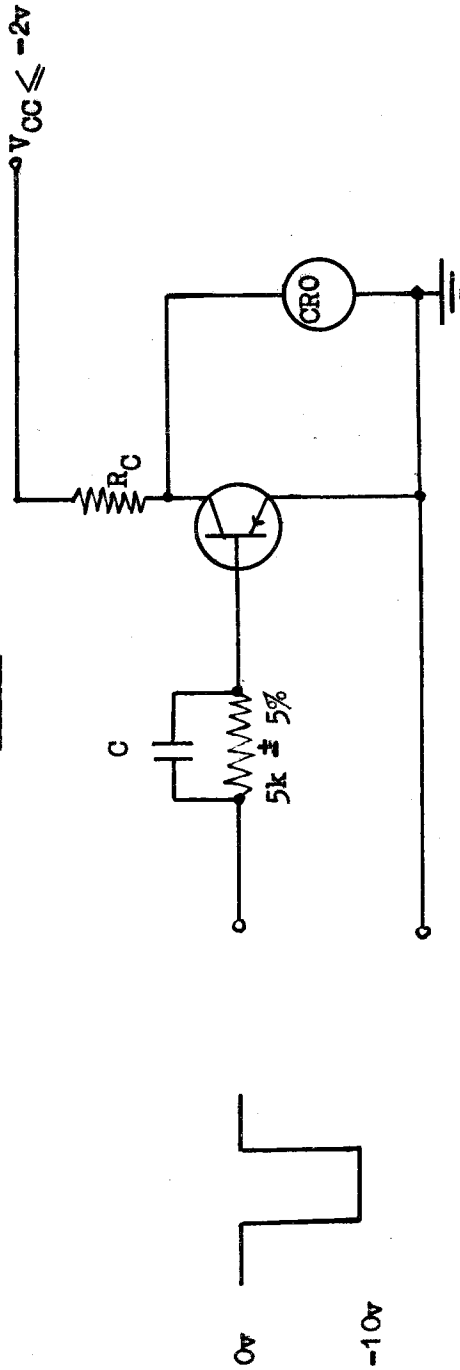

The circuit shown above is for PNP transistors CV7352-55. For NPN transistors CV7348-51,  $V_{CC}$  and the base input pulse should be +10volts.

10% - 90% rise and fall times of the pulse  $\leq 50$  nsecs

P.R.F.  $\leq 100$  kc/s

$R_C$  is chosen to give  $I_C < 2$  mA

For CV7348, CV7349 and CV7352-55  $C = 200$  pF

For CV7350, CV7351  $C = 180$  pF

Under these conditions the transistor must switch off to within 5% of the final value of  $V_{CE}$  within 0.3  $\mu$ secs with no subsequent current rise.

$$T_s = \frac{Q_{OFF} (pC)}{I_B (mA)} = \frac{100}{2} \mu\text{secs}$$

C.R.O. Bandwidth 5Mc/s. Probe Capacitance  $\leq 20$  pF.



FIG 4

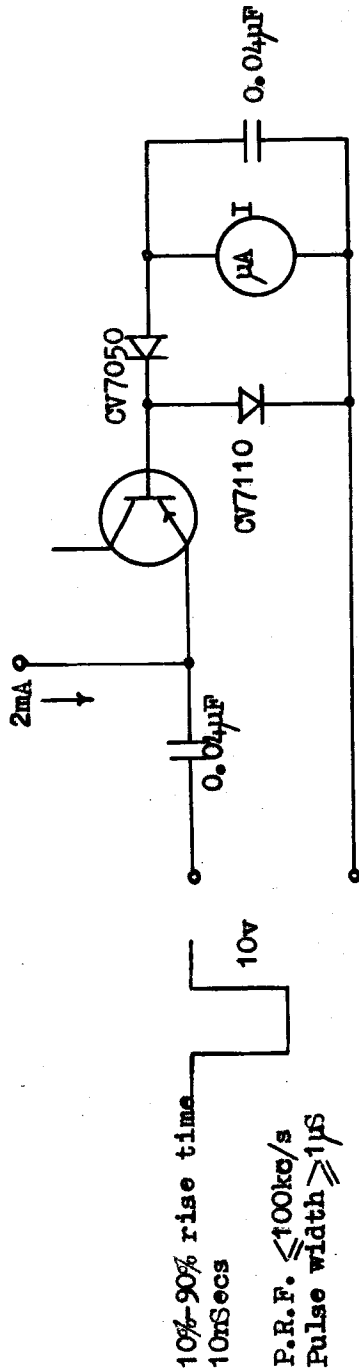

Pulse generator impedance  $\leq 100\text{ohms}$

The circuit shown above is for PNP transistors. For NPN transistors the base and emitter terminals should be inter-changed

$I_1$  is the current when  $I_F = 0$ .  $I_2$  is the current when  $I_F = 2\text{mA}$

$$T_s = \frac{I_2 - I_1}{2f} \text{ Secs}$$

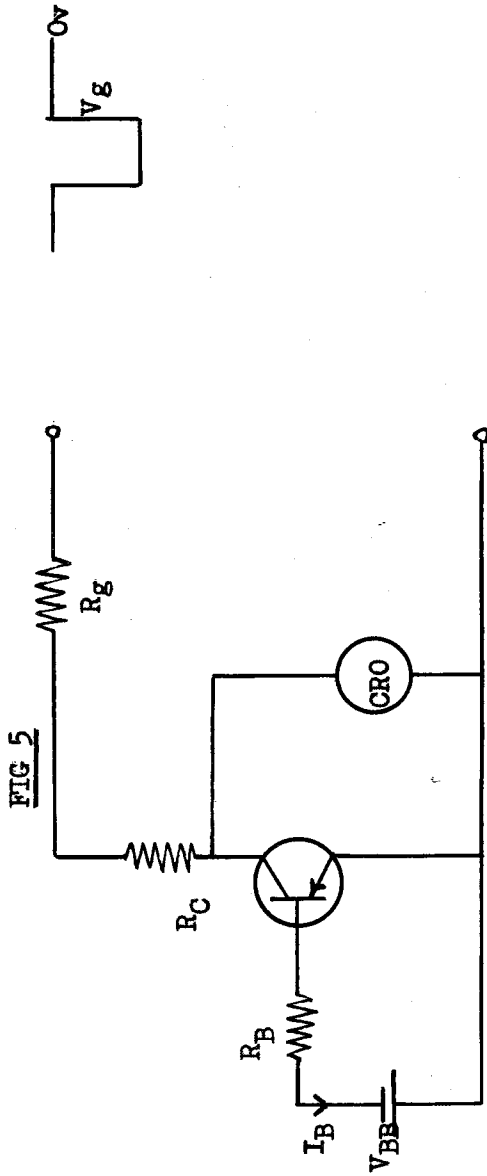

FIG 5

The circuit shown is for NPN transistors. For PNP transistors the polarity of  $V_{BB}$  and the collector pulse should be reversed.

During no part of the 'on' period should the value of  $V_{ce}$  exceed the limit value.

10% - 90% rise time  $\geq 20\text{nSecs}$   
 $\leq 50\text{nSecs}$

$t_{ON}$  and  $t_{OFF} \geq 5\mu\text{Secs}$

CRO bandwidth 5Mc/s. Probe capacitance  $\leq 20\text{pF}$

$R_B$  and  $V_{BB}$  should be chosen so that  $I_B$  is at the specified value for the transient saturation voltage test in Group A Sub-group 2.

$$\frac{V_g}{R_g + R_C} \text{ Should be chosen so that } I_C = 10\text{mA}$$

## APPLICATION DATA 1

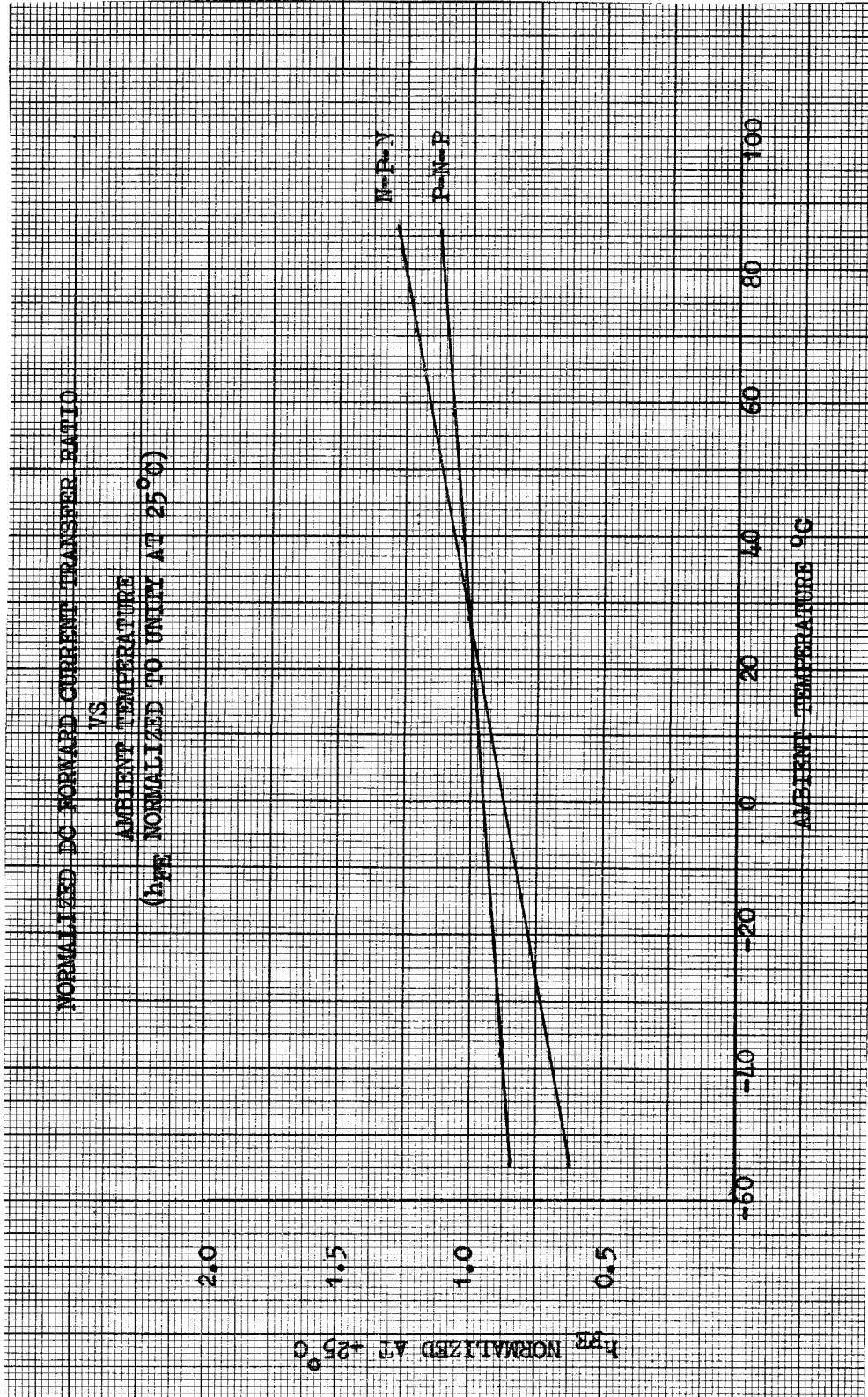

APPLICATION DATA 2

